



# User Guide

BT STUDIO 100



# Welcome...

to your BT Studio 100 Digital  
Cordless Telephone

- Use Caller Display to see who is calling before you pick up the phone and keep track of incoming calls with the 30 number Calls list.
- Use the phonebook to store and dial up to 30 of most frequently used phone numbers.
- As a Digitally Enhanced Cordless Telecommunications (DECT) product, your BT Studio 100 provides digital quality call clarity.

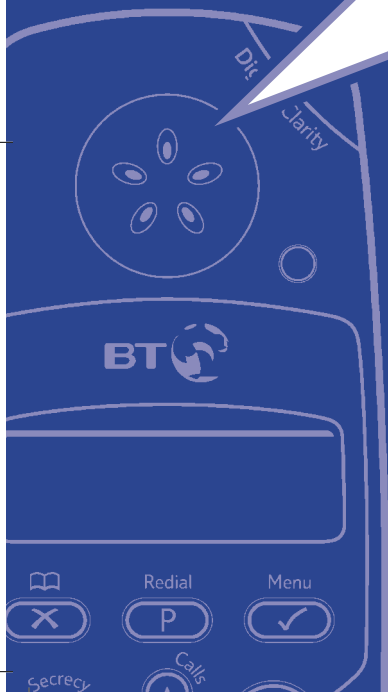

This User Guide provides you with all the information you need to get the most from your phone.

Before you make your first call you will need to set up your phone. Follow the simple instructions in ‘Getting Started’, on the next few pages.

■ **Need help?**

If you have any problems setting up or using your BT Studio 100 please contact the Helpline on **0870 605 8047**.

Alternatively, you may find the answer in ‘Help’ at the back of this guide.

**Got everything?**

- BT Studio 100 handset
- BT Studio 100 base
- 2 x AAA NiMH rechargeable batteries
- Mains power adaptor
- Telephone line cord

**If you have purchased the BT Studio 100 Twin you will also have:**

- BT Studio 100 additional handset
- BT Studio 100 charger
- 2 x AAA NiMH rechargeable batteries
- Mains power adaptor

# In this guide

## Getting started

Location . . . . .	6
Setting up the base . . . . .	6

## Getting to know your phone

Handset buttons . . . . .	9
Sample standby screen . . . . .	10
Base buttons and LEDs . . . . .	11
Navigating the menus . . . . .	12
Menu map . . . . .	12

## Using the phone

Switching the handset power on/off . .	13
Make an external call . . . . .	13
Preparatory dialling . . . . .	13
End a call . . . . .	13
Receiving calls . . . . .	13
Call timer . . . . .	14
Earpiece volume . . . . .	14
Handset ringer volume . . . . .	15
Secrecy . . . . .	15
Redial . . . . .	15
Last number redial . . . . .	16
Delete a redial number . . . . .	16
Delete the redial list . . . . .	16

## Phonebook

Store a phonebook entry . . . . .	17
Character map . . . . .	18
Dial a phonebook entry . . . . .	19
Delete a phonebook entry . . . . .	19
Edit a phonebook entry . . . . .	20

## Caller Display and the calls list

View and dial a calls list entry . . . . .	22
Delete a calls list entry . . . . .	22
Delete all calls list entries . . . . .	23
Copy a calls list entry to the phonebook . . . . .	23
Call Waiting . . . . .	24

## Handset settings

To change the external ringer melody .	25
To change the external ringer volume .	26
To change the internal ringer melody .	26
To change the internal ringer volume .	27
Switch beeps on/off . . . . .	28
Auto answer . . . . .	28
Selecting a language . . . . .	29
To switch key lock on . . . . .	30
Quick Key lock . . . . .	31
To switch key lock off . . . . .	31
Naming a handset . . . . .	31

## Base settings

To change the base PIN code . . . . .	32
De-register a handset from the base . .	33
To change the ringer melody . . . . .	33
To change the ringer volume . . . . .	34
Reset if you have forgotten your PIN code . . . . .	35

## Using additional handsets

Registering a new GAP compatible handset to your BT Studio 100 base . .	36
Internal calls . . . . .	37
Receiving internal calls . . . . .	37
Paging . . . . .	37
Transferring calls . . . . .	38

## Using additional bases

Registering your BT Studio 100 handset to another base . . . . .	39
Selecting a base to use . . . . .	40

Help . . . . .	42
----------------	----

## General information

Safety . . . . .	45
General . . . . .	45
Cleaning . . . . .	46
Environmental . . . . .	47
Guarantee . . . . .	48
Returning your phone . . . . .	49
How many telephones can you have? .	50
R&TTE . . . . .	50
Declaration of Conformance . . . . .	51
Switchboard compatibility . . . . .	51
Switchboard external line access code . . . . .	51
To insert a pause . . . . .	52
Recall . . . . .	52
Dialling mode . . . . .	52
Temporary change to dialling mode . .	53

# Getting started

## WARNING

Do not place your BT Studio 100 in the bathroom or other humid areas.

## Handset range

The handset reception range from the base is up to 300m outdoors and up to 50m indoors, in ideal conditions.

## Signal strength

The  icon on your handset indicates when you are in range. When it flashes, you are out of range.

When you move out of range of the base, you will hear the out of range tone. This tone is repeated until you move back into range.

## IMPORTANT

The base station must be plugged into the mains power socket at all times.

Do not connect the telephone line until the handset is fully charged.

## Which socket?

 Power socket

 Telephone line socket

## Location

You need to place your BT Studio 100 close enough to a mains power and telephone socket so that the cables will reach.

The strength of the handset signal depends on where you site the base. Make sure it is at least 1 metre away from other electrical appliances to avoid interference.

## Setting up the base

1. Plug the power adaptor and telephone cable into the back of the base.

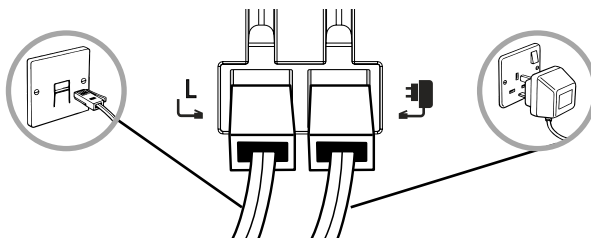

2. Plug the power adaptor into the mains wall socket and switch the power on. When connected correctly, the green Power light on the base comes on.

3. Install the 2 x AAA rechargeable batteries supplied.  
Then slide the battery compartment cover into place.

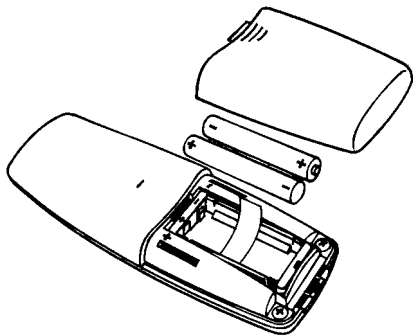

With batteries installed the display will show:



The  icon will flash while the handset searches for the base.

4. Place the handset in the base to charge, the red charging light comes on and the  icon begins scrolling.

#### Talk/Standby time

In ideal conditions, the handset batteries should give about 10 hours talk time or 100 hours standby on a single charge. The base must remain plugged in to the mains and switched on at all times.

Note that new batteries do not reach full capacity until they have been in normal use for several days.

#### Battery symbols

 - Battery fully charged

 - Battery half charged

 - Battery low

#### Battery low warning

If the battery charge becomes low during a call you will hear a warning beep every minute (provided the battery warning tone is set to on, see page 26). If the battery runs out you will be cut off. You will need to recharge the handset before using it again.

During charging, the (battery) icon will scroll in the display.

## 8 Getting started

### Battery performance

To keep your batteries in the best condition, leave the handset off the base for a few hours at a time. Running the batteries right down at least once a week will help them last as long as possible.

The charge capacity of rechargeable batteries will reduce with time as they wear out, giving the handset less talk/standby time. Eventually they will need to be replaced. New batteries are available from the BT Studio 100 Helpline on 0870 605 8047.

After charging your handset for the first time, subsequent charging time is about 6–8 hours a day. Batteries and handset may become warm during charging. This is normal.

When the handset has linked with the base the idle display will be shown:

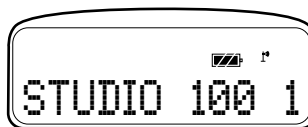

You should charge the handset for at least 16 hours on first charge.

5. Once fully charged, plug the telephone line cord into the telephone wall socket.

**Your BT Studio 100 is ready for use.**

# Getting to know your phone

9



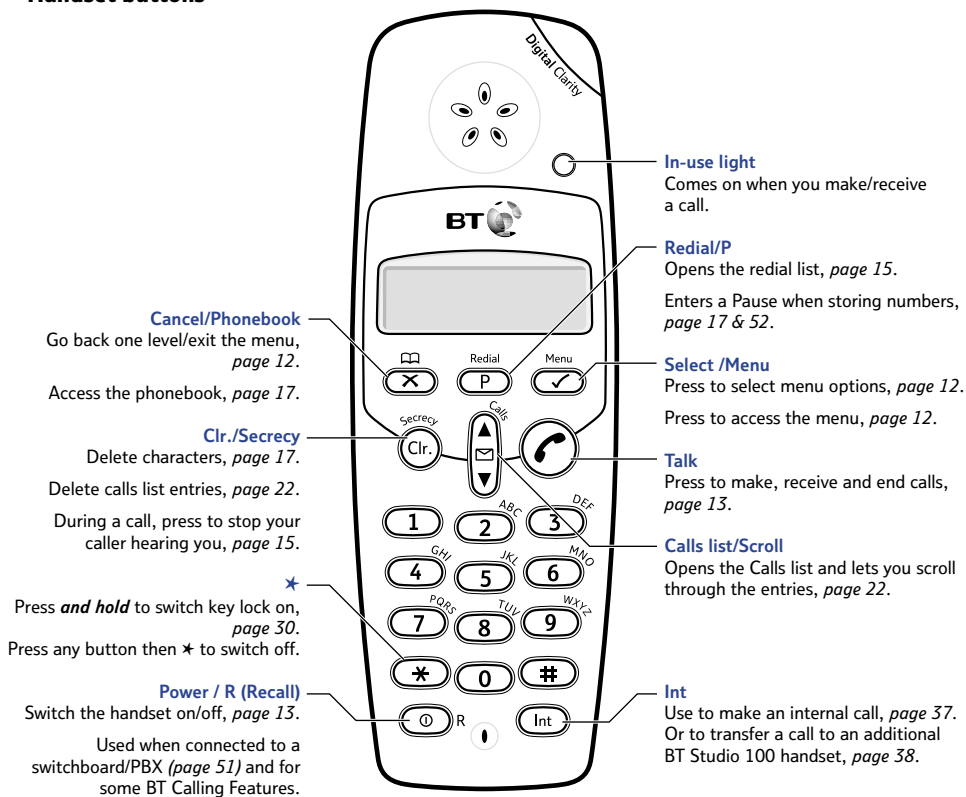





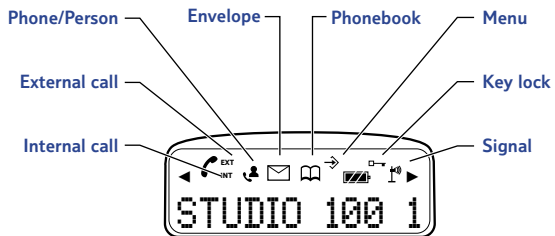

## Handset buttons



## 10 Getting to know your phone

**Sample standby screen** – These are where the handset icons will appear.



- |  |  |
|--|--|
| <p> <b>(TALK)</b><br/>Indicates a call is in progress, <i>page 13</i>.</p> <p><b>EXT</b> <b>EXT</b><br/>Flashes when you receive an external call. Stays on during the conversation, <i>page 13</i>.</p> <p><b>INT</b> <b>INT</b><br/>Flashes when you receive an internal call. Stays on during the internal conversation, <i>page 37</i>.</p> <p> <b>(ENVELOPE)</b><br/>Flashes when you have new calls in the Calls list. On when viewing the Calls list, <i>page 21</i>.</p> <p> <b>(PHONE/PERSON)</b><br/>When viewing the Calls list, indicates an answered call, <i>page 22</i>.</p> <p> <b>(PERSON)</b><br/>When viewing the Calls list, indicates an unanswered call, <i>page 22</i>.</p> | <p> <b>(PHONEBOOK)</b><br/>Displayed when you are dialling or storing numbers in the phonebook, <i>page 17</i>.</p> <p> <b>(MENU)</b><br/>Displayed when you are using the menus, <i>page 12</i>.</p> <p> <b>(BATTERY CHARGED)</b><br/>Indicates when the battery is fully charged, <i>page 7</i>.</p> <p> <b>(BATTERY LOW)</b><br/>Indicates when the battery is low, <i>page 7</i>.</p> <p> <b>(KEY LOCK)</b><br/>Indicates when the Key lock is on, <i>page 30</i>.</p> <p> <b>(SIGNAL STRENGTH)</b><br/>Steady when handset is in range of the base. Flashes when out of range of the base or not registered to the base.</p> <p> <b>(&lt; and &gt;)</b><br/>Indicates hidden digits (when the displayed number is longer than 12 digits).</p> |
|--|--|

\* For these features to work you must subscribe to your Network Provider's Caller Display and/or Call Waiting service.

## Base buttons and LEDs

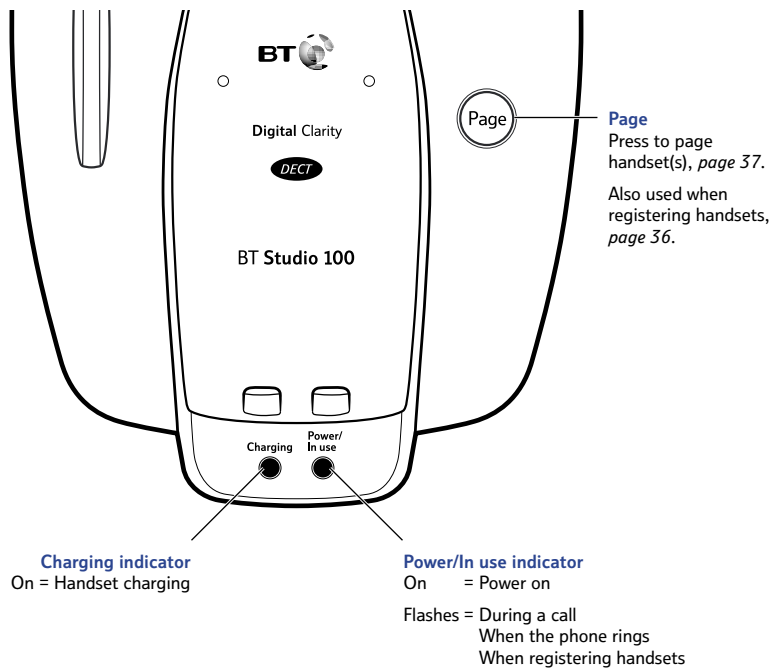





## 12 Getting to know your phone

Press  to exit a menu.  
Keep pressing to return to the idle screen at any time.

### Navigating the menus

Your Studio 100 handset has a menu system to guide you through the handset and base options. Refer to the menu map below for the available options.

*When the handset is displaying the idle screen:*

1. Press  to open the main menu.
2. Use  and  to scroll through the menu list.
3. When the menu item you want is displayed, press  to select and view the sub-menus available.

### Menu map

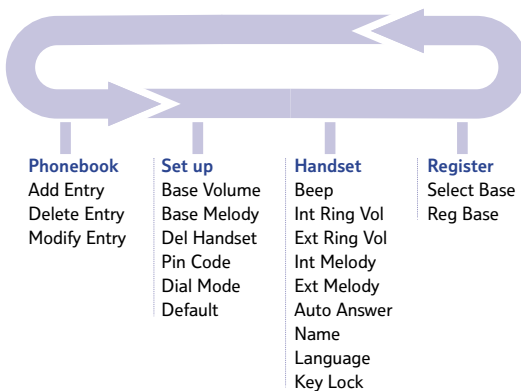



# Using the phone



## Switching the handset power on/off

Press *and hold* the  button.

## Make an external call

1. Press  listen for the dial tone then dial the number. The display shows the  and then the  icons.

## Preparatory dialling

1. Enter the number first. If you make a mistake, press  to delete the last digit.
2. Press  to dial.

## End a call

1. Press  or place the handset back on the base.

## Receiving calls

The base and handset will ring, the  icon flashes and CALL is displayed.

1. Press  to answer the call or, if the handset is on the base, simply lift it and speak.

## Dialling numbers quickly

Numbers can also be dialled using the phonebook (page 19), and from the calls list (page 22).

## Please note

The first digit of a telephone number you enter or receive via Caller Display, will not be shown on the screen. For example, the first 0 or 020 8123 4567 will not be displayed.

## 14 Using the phone

---

If you have subscribed to your network's Caller Display service, the caller's number, or name (if an exact name/number match is found in the phonebook) will also be displayed, *See page 21* for more information.

### **Call timer**

Your handset automatically times the duration of all calls, showing the time on the display during your call and for a few seconds after it has finished.

### **Earpiece volume**



There are 5 volume levels to select from. You can only adjust the earpiece volume *during a call*.

1. Press **▲** to increase or **▼** to decrease the earpiece volume. The display shows the set volume, e.g. EARVÖL 2.

### Handset ringer volume



There are 3 volume levels to select from, or you can set the volume to off.

*While the phone is ringing:*

1. Press  to increase or  to decrease the ringer volume. The display shows the set volume.



### Secrecy

During a call, you can talk to someone nearby without your caller hearing you.

1. During your call, press . MUTE is displayed and your caller cannot hear you.
2. Press  **again** to resume your call.

### Redial

Your handset automatically saves the last 5 numbers you dialled into a redial list.

1. Press .
2. Press  or  to scroll and display the number you want.

Each redial number can be up to a maximum of 32 digits long.

Only the last 12 digits of the number will be displayed.

If there are no numbers saved in the redial list **EMPTY** will be displayed.

## 16 Using the phone



Press  to exit a menu.  
Keep pressing to return to the idle display at any time.

If a name/number match is found in the phonebook the name will be displayed instead of the number.

Press  to toggle between the name and number.



3. Press  to dial the number.

### Last number redial

1. Lift the handset and press .
2. Press . The last number called is redialled.

### Delete a redial number

With the name or number you want to delete displayed:

1. Press . DELETE? is displayed.
2. Press  to confirm.

### Delete the redial list







With any number from the redial list displayed.

1. Press *and hold* . DELETE ALL? is displayed.
2. Press  to confirm.

# Phonebook

## Store a phonebook entry

You can use the phonebook to store up to 30 names and numbers for easy dialling. Each number can be up to 20 digits and each name up to 12 characters long.

1. Press  to display PHONEBOOK.
2. Press  to confirm.
3. Press  or  to select ADD ENTRY.
4. Enter a name using the keypad (*see character map, page 18*), then press .
5. Enter the telephone number, then press .
6. Select a ringer melody (1 to 3), then press . You hear a confirmation beep.

If your caller's details are matched to an entry in the phonebook then your handset will ring with the melody selected.

 icon is displayed while you are using the phonebook.

## Using the phonebook with additional handsets

If you are using more than one handset, each handset has a separate phonebook, so you can store 30 entries per handset.

## Deleting characters/digits

If you make a mistake, press .

## Cancel storing

Press  once to return to ADD ENTRY.

Press  repeatedly to exit.

## Entering names:

For example, to enter the name Tom:

Press 8 for T.

Press 6 three times for O.

Press 6 for M.

The maximum length for names is 12 characters.

You cannot store a name without a number.

## Inserting a Pause

You can insert a Pause in the dialling sequence. This can be useful if your phone is connected to an internal switchboard, see page 52.





## 18 Phonebook

### Character map









#### Digit button

1	BLANK	-	1		
2	A	B	C	2	
3	D	E	F	3	
4	G	H	I	4	
5	J	K	L	5	
6	M	N	O	6	
7	P	Q	R	S	7
8	T	U	V	8	
9	W	X	Y	Z	9

### Dial a phonebook entry

1. Press .
2. Enter the first letter of the name you want using the keypad, then scroll to the exact entry using  or .
3. Press  to dial the number.

### Delete a phonebook entry

1. Press .
2. Press  to confirm.
3. Press  or  to select DELETE ENTRY.
4. Press  to confirm.
5. Press  or  to select entry.
6. Press  to confirm. CONFIRM? is displayed.
7. Press  to confirm.



Phonebook entries are listed alphabetically.

If the number has more than 12 digits, press  again to display the remaining digits.













**To delete digits**

Press .

**To change individual characters**

Use  or  to move the cursor underneath the letter you want to change, then overwrite the correct letter.

**Edit a phonebook entry**

1. Press . Display shows PHONE BOOK.
2. Press .
3. Press  or  to select MODIFY ENTRY.
4. Scroll to the entry you want using  or .
5. Press .
6. Use  or  to move through and the name, and edit using the keypad, then press .
7. Use  to delete digits and enter new number using the keypad, then press .
8. Select a ringer melody (1 to 3), then press .  
You hear a confirmation beep.

# Caller Display and the calls list

If you subscribe to a Caller Display service you can see your caller's number on your handset's display (unless it has been withheld) before you answer the call.

Whether you answer a call or not, the caller's phone number is stored in the calls list.

When you have new entries in the calls list the  icon will flash in the display.

When all the entries have been viewed, the  icon will disappear.

Up to 30 phone numbers can be stored in the calls list. When the calls list is full, a new call replaces the oldest.

Each stored number can be up to 20 digits and each name up to 12 digits long.

## IMPORTANT

To use Caller Display you must first subscribe to the service from your network provider. A quarterly fee is payable.

For more information on BT's Calling Features, call BT on Freephone 0800 800 150.

## Caller information not available

Occasionally the telephone number of the caller is not available and cannot therefore be displayed.

In this case, your BT Studio 100 will show one of the following explanatory messages:

WITHHELD  
UNAVAILABLE  
INTERNATIONA(L)  
OPERATOR  
PAYPHONE  
RINGBACK

If the telephone number is longer than 12 digits, then only the last 12 digits will be displayed.

## 22 Caller Display and the calls list

### Using the calls list with additional handsets

If you are using more than one handset, each handset has a separate calls list.





### What type of call?

The  icon indicates a new call waiting to be viewed.

The  icon will be displayed for calls that you answered.

The  icon will be displayed for unanswered calls.





### View and dial a calls list entry

1. Press  or  *repeatedly* to open the calls list and then scroll through the entries. For each entry, the callers number is displayed, or their name if a name/number match is found in the phonebook.
2. When viewing an entry press  *repeatedly* to view the details for the entry: the caller's number, and the date and time the call was received.
3. Press  to dial the displayed number.





Or

Press  to exit the calls list and return to the idle screen.







### Delete a calls list entry

1. Press  or  to open the calls list and scroll to the entry you want.
2. Press . DELETE? is displayed.
3. Press  to confirm.
4. Press  to return to the idle screen.

### Delete all calls list entries

1. Press  or  to open the calls list.
2. Press **and hold**  until DELETE ALL? is displayed.
3. Press  to confirm (or  to cancel).

### Copy a calls list entry to the phonebook

1. Press  or  **repeatedly** to open the calls list and scroll to the entry you want to copy.
  2. Press  **twice**.  
Add? is displayed
  3. Press .
  4. Enter the name, then press .
  5. You can edit the number (if required), then press .
  6. Select a ringer melody (1 to 3), then press .
- You will hear a confirmation beep.

## Call Waiting

Providing you have subscribed to your network's provider's Call Waiting service, you will hear a soft beep every 5 seconds if an incoming call arrives while you are already on the phone. This beep is not audible to the person you are speaking to. The second caller's number (and name if stored in the phonebook) will appear on the handset display.

Instead of the engaged tone, the second caller will hear an announcement asking them to hold the line.

### Speak to a second caller

1. Press **1** to answer the second call and put your current caller on hold. Press **1** again to return to your first caller and to switch between both callers.

*Or*

2. If you want to end the current call and pick up the waiting call, press **7**. The handset will ring. Press **7** again to connect to the waiting caller.

The second caller is only charged from the second you answer, not while they are waiting to be connected.











# Handset settings

You can choose a range of settings to suit your personal preferences.

## Handset ringer melody and volume

You have a choice of 3 melodies and 3 volume levels (or OFF). You can change the external ringer (ring for an external incoming call) or the internal ringer (ring for an internal call).

### To change the external ringer melody

1. Press  .
2. Press  or  until **HANDSET** is displayed.
3. Press  .
4. Press  or  until **EXT MELODY** is displayed then press  .
5. Press  or  to select a melody then press  .

The default setting is 1.











You can also assign a different ringer melody to entries in your phonebook, see page 17.

## 26 Handset settings











The default setting is 2.

The default setting is 1.











### To change the external ringer volume

1. Press .
2. Press  or  until **HANDESET** is displayed.
3. Press .
4. Press  or  until **EXT RING VOL** is displayed then press .
5. Press  or  to select a volume then press .

### To change the internal ringer melody

1. Press .
2. Press  or  until **HANDESET** is displayed.
3. Press .
4. Press  or  until **INT MELODY** is displayed then press .
5. Press  or  to select a melody then press .

### To change the internal ringer volume

1. Press .
2. Press  or  until HANDSET is displayed.
3. Press .
4. Press  or  until INT RING VOL is displayed then press .
5. Press  or  to select a volume then press .

The default setting is 2.

## Key beeps

Your BT Studio handset emits beeps to alert you to certain situations. You can set the handset to beep:

- If the battery is low.
- If you go out of range of the base.
- To beep as confirmation each time a handset button is pressed.







These beeps can be switched ON or OFF.

However, beeps which confirm settings cannot be switched off.

The default setting for all key beeps is ON.

## 28 Handset settings



### Switch beeps on/off

1. Press  .
2. Press  or  until **HANDESET** is displayed.
3. Press  .
4. Press  or  to display the type of beeps you want, then press  .

KEYTONE – for handset button beeps

LOW BATTERY – for low battery warning beeps

OUT RANGE – for out of range warning beeps

5. Press  or  to select **ON** or **OFF** then press  .







The default setting is **ON**.

### Auto Answer









When you receive a call, you can answer it by lifting the handset off the base station, this is called auto answer.

When you switch auto answer off, all calls must be answered by pressing  .

1. Press  .
2. Press  or  until **HANDESET** is displayed.
3. Press  .

4. Press  or  until AUTO ANSWER is displayed then press .
5. Press  or  to select ON or OFF then press .

## Selecting a language

1. Press  .
2. Press  or  until HANDSET is displayed.
3. Press  .
4. Press  or  until LANGUAGE is displayed.
5. Press  or  until the language you require is shown.  
Choose from ENGLISH, FRANCAIS, DEUTSCH, ITALIANO,  
DK/NOR/SVE.
6. Press  to confirm.

## 30 Handset settings

The default setting is OFF.







### **WARNING**

While key lock is switched on, it is NOT possible to make calls, including to emergency numbers (999/112).

## Key lock

You can lock the keypad so that it cannot be used accidentally while carrying the handset around.

### **To switch key lock on:**

1. Press .
2. Press  or  until **HANDSET** is displayed.
3. Press .
4. Press  or  until **KEY LOCK?** is displayed then press .

The  icon is displayed on the idle screen while the keypad is locked.

### Quick Key lock









1. Press **and hold**  for 3 seconds.

### To switch key lock off:

1. Press any key and the display shows PRESS \*.
2. Press  and the display returns to the idle screen.

## Naming a handset

Each handset registered to the base is assigned a number. You can give a handset a name as well as a number to match the user or location e.g. Anne or office. The name can be up to 10 characters long.

1. Press .
2. Press  or  until HANDSET is displayed.
3. Press .
4. Press  or  until NAME is displayed then press .
5. Enter a name using the keypad, then press .

The new handset name will replace the handset name in the display. The handset number will be shown on the far right hand corner.

# Base settings













The default setting is 0000.

You can choose a range of settings to suit your personal preferences.



## Security PIN

Your Studio 100 has a security PIN code which you will need to change some of the base settings. The default setting is 0000. You may want to change this to prevent unauthorised changes to your settings.

### To change the base PIN code

1. Press  .
2. Press  or  until SETUP is displayed then press .
3. Press  or  until PIN CODE is displayed then press .
4. Enter your old 4 digit PIN then press .
5. Enter your new 4 digit PIN then press .
6. Enter your new 4 digit PIN again for verification then press .
7. Press  *twice* to return to the idle screen.







### De-register a handset from the base

1. Press .
2. Press  or  until SETUP is displayed then press .
3. Press  or  until DEL HANDSET is displayed then press .
4. Enter your 4 digit PIN then press .
5. Enter the handset you want to de-register then press .
6. Press  *twice* to return to the idle screen.

## Base ringer melody and volume

You have a choice of 3 melodies and 3 volume levels (or volume OFF).

### To change the ringer melody

1. Press .
2. Press  or  until SETUP is displayed then press .
3. Press  or  until BASE MELODY is displayed then press .





The default setting is 1.

## 34 Base settings











The default setting is 2.

### WARNING









If you reset the handset and base, you will lose any names or numbers stored in the phonebook, redial list and calls list.

4. Press  or  to select a melody then press .
5. Press  **twice** to return to the idle screen.



### To change the ringer volume

1. Press .
2. Press  or  until SETUP is displayed then press .
3. Press  or  until BASE VOLUME is displayed then press .
4. Press  or  to select a volume then press .
5. Press  to return to the idle screen.

### Reset the handset and base

1. Press .
  2. Press  or  until SETUP is displayed then press .
  3. Press  or  until DEFAULT is displayed then press .
  4. Enter your 4 digit PIN then press .
- Your BT Studio 100 will reset itself to the default settings.

### Reset if you have forgotten your PIN code

1. Press **and hold**  to switch the handset off and remove the handset batteries, *see page 13*.
2. Replace the batteries. When the handset comes back on, press . DEFÄULT is displayed.
3. Press . The handset and base will automatically reset.

# Using additional handsets

## IMPORTANT

You must choose a handset that is GAP compatible to use with your BT Studio 100.

If the handset does not locate the base, the handset will return to the previous menu. Try to register again by using a different available base number. Ensure that you are in close vicinity of the base).

If you purchase a new handset to use with your BT Studio 100 it will have to be registered to the base. You will need to do this before you can use it.

If you have purchased a BT Studio 100 Twin the 2nd handset comes pre-registered to the base.

Only 2 handsets can be registered to your BT Studio 100 base at any time.

With 2 handsets, you can make internal calls, page handsets and transfer external calls between your handsets.

## Registering a new GAP compatible handset to your BT Studio 100 base

At the new handset:

1. Follow the new handset's user guide to set the handset in registration mode.

At the BT Studio 100 base:

1. Press **and hold** the base  button for at least 10 seconds, until you hear the validation tone (two beeps), then **release** the button.

### Internal calls



You can make internal calls between 2 BT Studio 100 handsets.

1. Press **Int**.
2. Enter the other handset number using the keypad ( **1** or **2** ).  
The called handset will ring.

If there is no response, press  to end the call at your handset.

The  icon are displayed on both handsets during an internal call.

### Receiving internal calls

1. When the handset rings, press  to answer.
2. Press  again to end the call.

### Paging

You can alert handset users that they are wanted or locate a missing handset. Paging calls cannot be answered by a handset.

1. Press **Page** on the base. The handset(s) and base will ring for 30 seconds.
2. Press any button on the handset, or press **Page** *again* on the base to stop the paging ring.

If, after 1 minute 45 seconds, the other handset has not answered, you will be automatically re-connected to the caller.

### Transferring calls

You can transfer an external call to the other handset.

During an external call:

1. Press **Int** . Your caller is put on hold and the other handset will ring.
2. When the handset answers, press **↻** to transfer the call.







If the other handset does not answer, press **Int** to talk to the caller again.

# Using additional bases

Your BT Studio 100 handset can be registered to up to 4 other bases.

## Registering your BT Studio 100 handset to another base

On the handset:

1. Press  .
2. Press  or  until REGISTER is displayed then press  .
3. Press  or  until REG BASE is displayed then press  .
4. BASE 1 2 3 4 will be displayed.

The base that you are currently registered to will flash.

5. Enter the number of the base you want to register to. SEARCH 1 is displayed (where 1 is the base number you are searching for).

When the base is located, you will hear a confirmation tone and PIN? will be displayed.

6. Enter the base PIN code.  
You hear a tone to confirm you have entered the correct code and the handset returns to idle mode.

### IMPORTANT

You can only register your BT Studio 100 handset to another base if it is GAP compatible.

You will not be able to register your BT Studio 100 handset to a BT Studio or BT Studio 500 base as these products are not GAP compatible.

The default PIN code is 0000.

## 40 Using additional bases

If registration is unsuccessful, after 1 minute, the handset will display the list of registered bases and you can try again or select another base to use.

If you are in an environment where there is a lot of electrical interference you may experience difficulty registering to a base.

On the base:







7. Press **and hold**  to put the base into registration mode.

The base beeps and the In use light flashes while the handset is registered.

Once registered you will hear a confirmation tone and the next available handset number is allocated and shown in the display.

### Selecting a base to use

If your handset has been registered to more than one base you can select which one it uses.

1. Press .
2. Press  or  until REGISTER is displayed then press .
2. Press  or  until SELECT BASE is displayed then press .
3. All bases that your handset is registered to will be displayed, e.g. BASE 1 2 3 4

The base that you are currently registered to will flash.

4. Enter the number of the base you want to use.

Or

Press  or  to select AUTO.

When the handset locates the selected base you will hear a confirmation tone.

If AUTO is selected the handset will automatically link to another base with a strong signal, if the signal it is currently receiving from its present base becomes very poor.

# Help

Many common problems are caused by the telephone and power cables being incorrectly connected, not connected at all, or the power being turned off.

Please check that your BT Studio 100 has been correctly set up, see page 6, before ringing the BT Studio 100 Helpline.

<b>Problems</b>	<b>Possible cause</b>
<b>No display</b>	The batteries may be flat or dead. Recharge or replace the batteries, see page 7.
<b>No dial tone</b>	Is the telephone line cord plugged into the telephone wall socket?  Check that the base station is connected to the mains power and switched on.
<b>You cannot link up with the base station</b>	Is the  icon flashing in the display?  The mains power cable may not be connected at the base or switched on.  Are you in range of the base? Move closer to the base.  The batteries could be low or flat.  Recharge or replace the batteries.

<b>Problems</b>	<b>Possible cause</b>
<b>No ring on the handset</b>	<p>Check that the base station is plugged into the phone socket and that the mains power is switched on.</p> <p>The ringer volume may be set too low for you. <i>See page 15</i> to adjust the volume.</p>
<b>Buzzing noise on my radio, TV, computer or hearing aid</b>	<p>Sometimes your BT Studio 100 can interfere with other electrical equipment if it is placed too close.</p> <p>It is recommended that you place your BT Studio 100 at least one metre away from such appliances to avoid any risk of interference.</p>
<b>The handset charger is not working</b>	<p>Check that the power adaptor is properly plugged into the charger.</p> <p>Make sure your handset has slotted correctly into the charger.</p> <p>Check the batteries are fitted correctly into the handset.</p> <p>Check the base is plugged in to a working mains power socket and that the power is switched on. Are you using the correct power adaptor?</p>

## 44 Help

Problems	Possible cause
<b>Caller's number is not displayed even though you have subscribed to Caller Display service</b>	The number has been withheld by the caller, is unavailable or is an international call, <i>see page 21</i> .

### BT Studio Helpline 0870 605 8047

Call the dedicated BT Studio Helpline:

- if you are having difficulties using your BT Studio 100
- if you need replacement batteries or mains power lead

Lines open

9am – 5.30pm, Monday to Friday.

9.30am – 2.30pm, Saturdays.

### BT Accessories and Replacement Items

For a full range of accessories and replacement items for BT products please call 0870 240 5522, or visit:



# General information

## Safety

### General

- Only use the power supply included with the product. Using an unauthorised power supply will invalidate your guarantee and may damage the telephone. The item code for the mains power supply is 872260.
- For the handset use only approved Nickel Metal Hydride (NiMH) rechargeable batteries. Never use other batteries or conventional alkaline batteries. They could lead to a short circuit or destroy the battery casing.
- Recommended batteries should have a power rating of 550mAh 1.2V. Batteries are available from the BT Studio 100 Helpline **08706 058 047**.
- Do not open the handset or base (other than to change batteries. This could expose you to high voltages or other risks. Contact the helpline for all repairs.
- It is recommended that advice from a qualified medical expert be sought before using this product in the vicinity of emergency/intensive care medical equipment.
- It is recommended that if you have a pacemaker fitted you check with a medical expert before using this product.

### Hearing aid?

Please note that the BT Studio 100 works by sending radio signals between the handset and base. These signals may interfere with some hearing aids, causing a humming noise.

### IMPORTANT

This equipment is not designed for making emergency telephone calls when the power fails. Alternative arrangements should be made for access to emergency services.

## 46 General information

---

- Your product may interfere with other electrical equipment, e.g. TV and radio sets, clock/alarms and computers if placed too close. It is recommended that you place your product at least one metre away from such appliances to minimise any risk of interference.
- Never dispose of batteries in a fire. There is a serious risk of explosion and/or the release of highly toxic chemicals.

### **Cleaning**

Simply clean the handset and base with a damp (not wet) cloth, or an anti-static wipe. Never use household polish as this will damage the product. Never use a dry cloth as this may cause a static shock.

## Environmental

- Do not expose to direct sunlight.
- The product may heat up when the battery pack is being recharged. This is normal. However, we recommend that you do not place the product on antique/veneered wood to avoid damage.
- Do not stand your product on carpets or other surfaces which generate fibres, or place it in locations preventing the free flow of air over its surfaces.
- Do not submerge any part of your product in water and do not use it in damp conditions, such as bathrooms.
- Do not expose your product to fire, explosive or other hazardous conditions.
- There is a slight chance that your phone could be damaged by an electrical storm.

We recommend that you unplug the power and telephone line cord for the duration of the storm.

## 48 General information

**For your records**

Date of purchase:

Place of purchase:

Serial number:

For guarantee purposes proof of purchase is required so please keep your receipt.

Enter your base PIN here:

[ / / / ]

(see page 32 for more information)

## Guarantee

Your BT Studio 100 digital cordless telephone is guaranteed for a period of 12 months from the date of purchase.

Subject to the terms listed below, the guarantee will provide for the repair of, or at BT's or its agent's discretion the option to replace the BT Studio 100, or any component thereof, (other than batteries), which is identified as faulty or below standard, or as a result of inferior workmanship of materials. Products over 28 days old from the date of purchase may be replaced with a refurbished or repaired product.

**The conditions of this guarantee are:**

- The guarantee shall only apply to defects that occur within the 12 month guarantee period.
- Proof of purchase is required.
- The equipment is returned to BT or its agent as instructed.
- This guarantee does not cover any faults or defects caused by accidents, misuse, fair wear and tear, neglect, tampering with the equipment, or any attempt at adjustment or repair other than through approved agents.
- This guarantee does not affect your statutory rights.

### **Within the 12 month guarantee period:**

If you experience difficulty using the product, prior to returning it, please read the 'Help' section beginning on page 41, or contact the BT Studio 100 Helpline on **0870 605 8047**, 9am–5.30pm, Monday to Friday and 9.30am–2.30pm, Saturday.

In the unlikely event of a defect occurring, please follow the Helpline's instructions for replacement or repair.

### **Outside of the 12 month guarantee period:**

If your product needs repair after the guarantee period has ended, the repair must meet the approval requirements for connection to the telephone network. We recommend that you contact BT's approved repair agent, TecLogic on **01672 564444** or a local qualified repairer.

### **Returning your phone**

If the Helpline is unable to remedy your problem they will ask you to return the product. Where possible, pack the product in its original packaging. Please remember to include all parts, including the line cords, power supply units and the original batteries. (Please note that we cannot take responsibility for goods damaged in transit.) Please obtain and keep proof of posting from the Post Office.

## Technical information

### How many telephones can you have?

All items of telephone equipment have a Ringer Equivalence Number (REN), which is used to calculate the number of items which may be connected to any other telephone line. Your BT Studio 100 has a REN of 1. A total REN of 4 is allowed. If the total REN of 4 is exceeded, the telephone may not ring. With different telephone types there is no guarantee of ringing, even when the REN is less than 4.

Only use the approved power supply, item code 872260.

Only use approved AAA NiMH rechargeable batteries.

### R&TTE

This product is intended for use within the UK for connection to the public telephone network and compatible switchboards.

This equipment complies with the essential requirements for the Radio Equipment and Telecommunications Terminal Equipment Directive 1999/5/EC.

### **Declaration of Conformance**

Hereby, Suncorp Technologies, declares that this BT Studio 100 is in compliance with the essential requirements and other relevant provisions of Directive 1999/5/EC.

The Declaration of Conformance for the BT Studio 100 is published on the website:

**<http://www.suncorptech.com/bt>**

### **Switchboard compatibility**

This product is intended for use within the UK for connection to public telephone network and compatible switchboards, which support tone dialling and timed break recall. If in doubt please consult your network service provider.

### **Switchboard external line access code**

You may need to enter an access code (e.g. **9**) in order to get an outside line. So that the switchboard has time to pick up an outside line, you may also need to add a Pause after the access code.

## 52 General information

For more information on storing numbers see 'Store a phonebook entry' on page 17.

### Pause

You may also need to insert a pause when storing international dialling codes, charge card numbers and with other tele-banking facilities.

A Pause lasts 3 seconds. You can Pause dialling at any time by pressing the **P** button.

### To insert a pause







1. Begin storing a number and press **P** where a pause is needed. P is shown in the display.





## Recall

The **R** button is used when connected to certain switchboards, e.g. to transfer calls, and for some BT Calling Features or those services available via your network provider.

## Dialling mode



Your BT Studio 100 is set to tone dialling. If required you can switch it to pulse dialling.

1. Press .
2. Press  or  until SETUP is displayed then press .
3. Press  or  until DIAL MODE is displayed then press .

4. Press  or  to select either TONE or PULSE then press .
5. Press  **twice** to return to the idle screen.



### Temporary change to dialling mode

If you have set your BT Studio 100 to Pulse dialling, you can temporarily switch to Tone dialling during a call.

1. Press , then press , then dial the number as normal.

Your BT Studio 100 will switch to Tone dialling only for the duration of this call.

Alternatively, you can store a phonebook number so that it will temporarily switch to Tone dialling each time it is dialled.

2. Press **and hold**  before you store the number in the phonebook.  is displayed.

Visit us at [www.bt.com](http://www.bt.com)



### Offices worldwide

The telecommunications services described in this publication are subject to availability and may be modified from time to time. Services and equipment are provided subject to British Telecommunications plc's respective standard conditions of contract. Nothing in this publication forms any part of any contract.

© British Telecommunications plc 2003.  
Registered Office: 81 Newgate Street, London EC1A 7AJ.  
Registered in England No. 1800000.  
BT Studio 100 (10/03) 4  
Designed and produced by The Art & Design Partnership Ltd.  
Printed in China

